

CORNELL PUMP COMPANY

PRIMING SYSTEMS

REDI-PRIME® AND VENTURI PRIME



Preferred Australian Mining Supplier &
Cornell Pump Partner

SOURCE
Bespoke Pumping Solutions

VENTURI PRIME SYSTEM

VALUE PRIMING OPTION + CORNELL QUALITY

The Cornell Venturi Prime system relies on a compressor driven by the pump shaft and lubricated by engine oil to blow air through the venturi and evacuate it from the suction line and pump casing. The venturi prime is economical and compatible with any Cornell Pump where Redi-Prime® is an option.

The Venturi Prime system is slower to prime than Redi-Prime, has superior performance in freezing temperatures, and can be tailored to the application. The Venturi Prime air compressor requires an external source for coolant and lubrication supplies, usually from the engine. Cornell's Venturi Prime system provides an excellent solution where cost is key, but quality is essential.

VENTURI PRIME BENEFITS

- Fully automatic priming and repriming
- Primes with reasonable speed
- Does not impede solids handling of the pump
- Can operate unattended
- Patented Cycloseal® and Run-Dry™ options
- No change in suction lift capacity and flow rates
- Available with manual valve for operation in colder climates

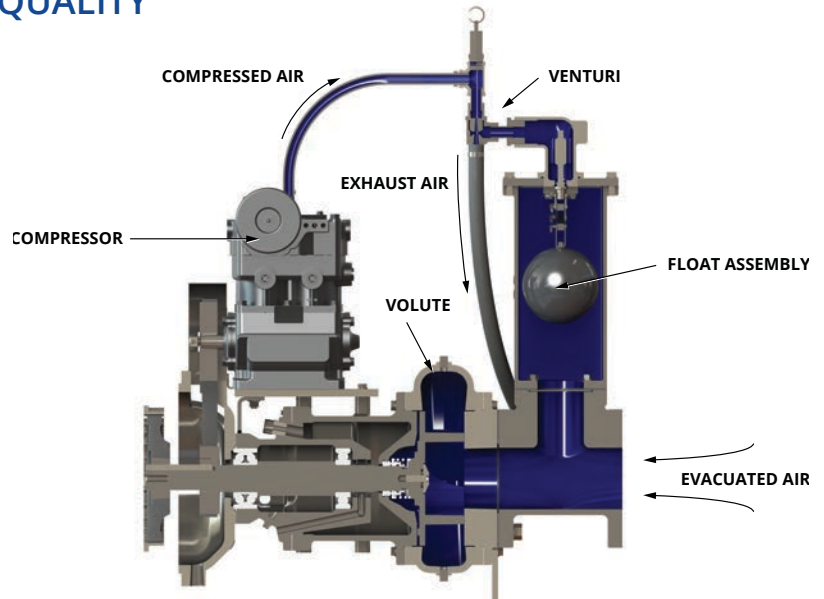

COMPARE REDI-PRIME® AND VENTURI-PRIME

SYSTEM	PRIMING SPEED	OPERATING TEMPERATURE	COST	CARRY-OVER CONTAINMENT
Redi-Prime®	Up to 50 CFM			 Excellent
Venturi Prime	Less than 20 CFM			 Fair

REDI-PRIME® SYSTEM

REDI-PRIME® SYSTEM OVERVIEW

Cornell's Redi-Prime® pumps are designed and engineered for the most rugged and demanding industries - construction, industrial, rental, and municipal. With over 70 years of proven experience and reliability, Cornell Pump Company has established the highest industry standard for premium quality and rugged performance. An industry-leading two-year warranty backs our pumps.

The Redi-Prime system uses a positive-sealing float box and a diaphragm vacuum pump to provide fully automatic priming and re-priming of the pump. There is no water carry-over to contaminate the environment, and Redi-Prime is compatible with most Cornell pump models.

REDI-PRIME® BENEFITS

- Fully automatic-priming and repriming
- Handles air/liquid mixtures with ease
- Rapidly primes and re-primers completely unattended
- Environmentally safe priming system designed to prevent product leakage
- Patented Cycloseal® and Run-Dry™ options
- Does not impede solids handling of pump
- No change in suction lift capacity and flow rates
- Check valve eliminates any liquid carry over

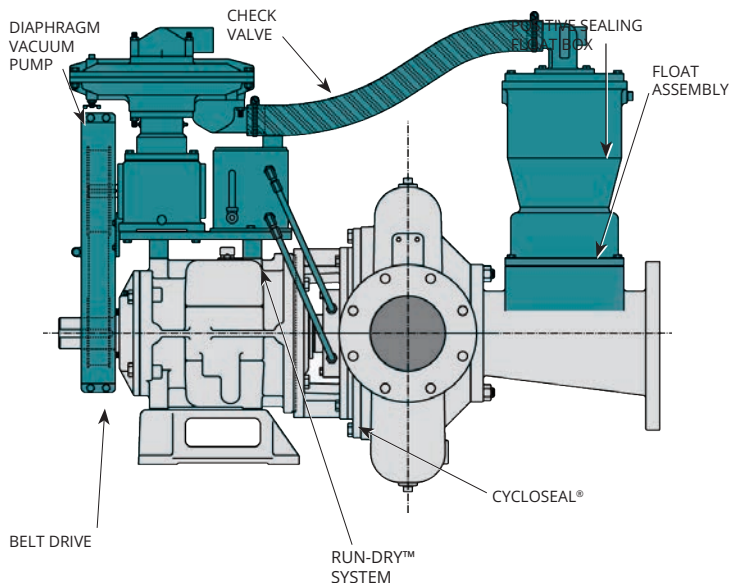

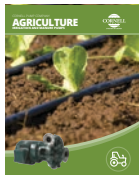

AGRICULTURE



FOOD PROCESS

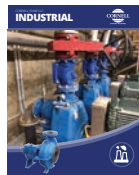

INDUSTRIAL



MINING

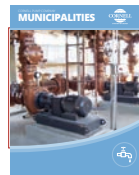

MUNICIPAL

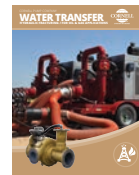

WATER
TRANSFER



REFRIGERATION

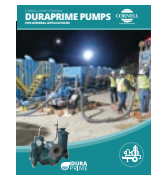

CONSTRUCTION

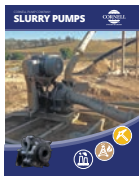

SLURRY

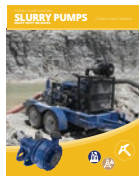

SLURRY SM

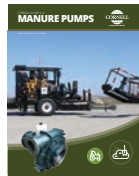

MANURE

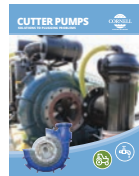

CUTTERS

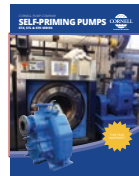

SELF PRIMING

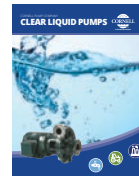

CLEAR LIQUIDS



MX SERIES

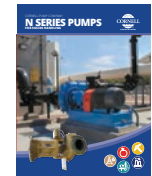

N SERIES

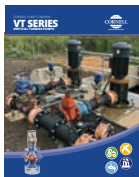

CYCLONE™

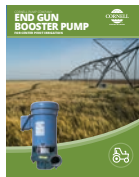

EDGE™



HYDRAULIC
SUBS



IMMERSIBLE



CD4MCU



RUN-DRY™



PRIMING
SYSTEMS

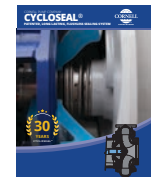

CYCLOSEAL®

Cycloseal® and Redi-Prime® are Registered Trademarks of Cornell Pump Company.

Cornell pumps and products are the subject of one or more of the following U.S. and foreign patents:

6,074,554; 6,036,434; 6,079,958; 6,309,169; 6,104,949.

23 - EV - BR - 701

CORNELLPUMP.COM
©2023 CORNELL PUMP COMPANY

SOURCE
Bespoke Pumping Solutions

PROUD PARTNER OF
CORNELL

Source Pumps PTY LTD
22 Peterpaul Way
Truganina, VIC 3029
sourcepumps.com.au
sales@sourcepumps.com.au



Certified to
ISO 9001:2015



Cornell Pump Company
Clackamas, Oregon, USA
P: +1 (503) 653-0330
F: +1 (503) 653-0338