

CORNELL PUMP COMPANY

RUN-DRY™

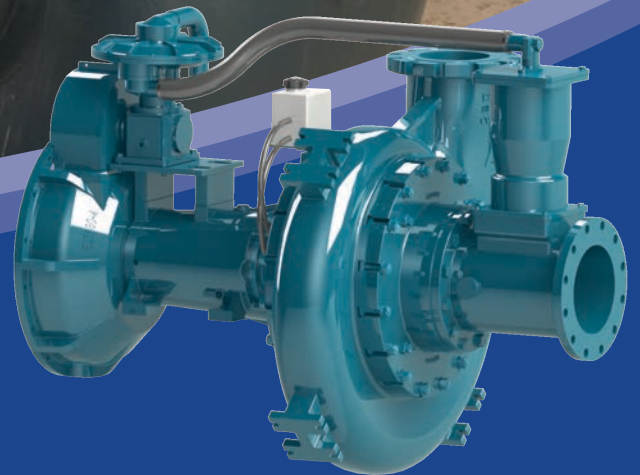

Preferred Australian Mining Supplier &
Cornell Pump Partner

SOURCE
Bespoke Pumping Solutions

RUN-DRY™ SYSTEM

FLUID RESERVOIR

The heart of Cornell's Run-Dry™ system is the ability to deliver lubrication/cooling to the seal during periods of no flow operation. Natural circulation of the fluid in the reservoir removes heat from the seal faces to keep them in pristine condition.

RUN-DRY™ GLAND

With Cornell's Run-Dry system, seal face cooling is effected by providing for heat exchange/lubrication in the area immediately adjacent to the seal faces. This small cavity is created by adding a gland which is connected to the reservoir to complete the lubrication/cooling circuit.

CYCLOSEAL®

Cornell's Run-Dry is an addition to the same Cycloseal system that protects our pumps during normal operating conditions. Truly a system, this combination of backplate deflector vanes, impeller backvanes and a quality type I or II mechanical seal, can also run dry, when equipped with the Run-Dry system.

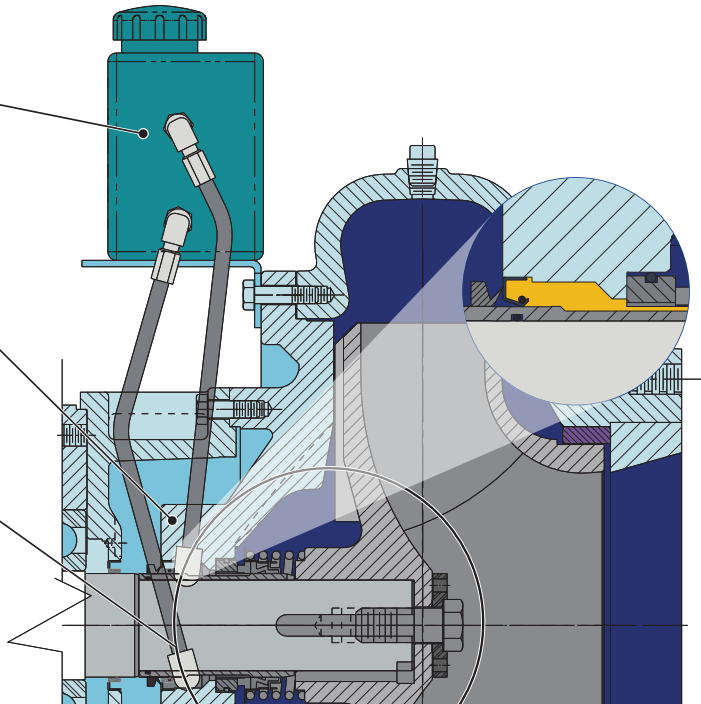

PROTECTS MECHANICAL SEALS FROM DAMAGE CAUSED BY OPERATING WITHOUT PUMPING FLUID—RUNNING DRY.

Cornell's innovative Run Dry system offers a solution for continuous lubrication of mechanical seals. This system features a gland on the backside of the mechanical seal that allows a lubricant to circulate, providing cooling and lubrication to the mechanical seal's hardened faces. The benefit of this technology is prolonged seal life, irrespective of the operating conditions, ranging from maximum flow to no flow. It truly enables running dry without any adverse impact on the seal's performance – hence the name Run-Dry.

FEATURES:

- ✓ Seal protection
- ✓ Seal cooling
- ✓ Easily-checked lubricant reservoir
- ✓ Ease in servicing and maintaining pumps
- ✓ Peace of mind if pump runs dry

Dry running can damage, even destroy, and seals in seconds—counteract the wear and leaks with Cornell Run-Dry™.

Dry operation could result from:

- Priming activities
- Blockage in suction piping
- Deliberate operation of the pump in dry conditions
- Accidental loss of prime while pumping

APPLICATIONS



AGRICULTURE



FOOD PROCESSING (FOOD GRADE LUBRICANT AVAILABLE)



INDUSTRIAL



MINING



OIL & GAS



MUNICIPAL



RENTAL



Any application where there is probability, either planned or unplanned, that the pump could operate in dry condition

RUN-DRY™ SYSTEM

OPERATION

The Run-Dry system from Cornell is an innovative solution that ensures continuous lubrication of mechanical seals. The system works by using a flexible hose to transport lubricant from the lower portion of the reservoir to the bottom of the Run-Dry gland, which is housed within the pump backplate and sealed on the drive end with a lip seal. The mechanical seal at the pump end of the gland is also protected by this relationship.

The Cornell Run-Dry gland features two ports that allow for the continuous flow of lubricant from the reservoir to the gland and back through the upper and lower ports, thanks to the pumping action of the rotating shaft. Additionally, heat generated by the mechanical seal is transferred back to the reservoir through lubricant circulation, which helps to dissipate the heat and ensure that there is always enough lubricant available for the Run-Dry gland.



RUN-DRY COMPLEMENTS TWO OTHER CORNELL PATENTED INNOVATIONS:

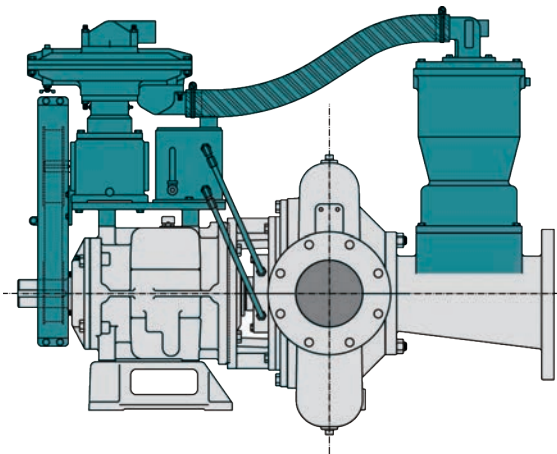

REDI-PRIME®

Cornell's Redi-Prime pumps feature generously sized suction ports, providing increased flow, reduced friction losses, and improved suction lift. The innovative dry priming system is patented and designed with environmental considerations in mind. The system utilizes a positive-sealing float box and a diaphragm vacuum pump, preventing any water carry-over and avoiding contamination of the environment. With suction lifts of up to 28 feet, heads reaching 800 feet, and flow rates exceeding 34,000 GPM, most Cornell pumps can be easily adapted to incorporate the Redi-Prime system.



CYCLOSEAL® SYSTEM

The Cycloseal system, available on most Cornell pumps, is a patented design that features a self-contained single mechanical seal. The pump backplate is cast in a Cycloseal pattern, with contoured impeller back vanes and a dished backplate, creating a pressure gradient that moves solids and entrained vapor away from the seal faces. This innovative system ensures optimal performance and extends the life of the seal.

- Grit and vapor removed from pump seal compartment
- Extended pump seal life — three times standard mechanical seals
- No drips/mess at application site
- Reduced maintenance costs
- Increased uptime and reliability

Run-Dry, Cycloseal, and Redi-Prime offer unparalleled reliability, performance, and durability as sealing and maintenance systems.

CORNELL PUMP COMPANY MARKET & PRODUCT LINE

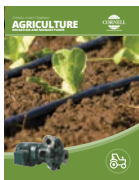

AGRICULTURE



FOOD PROCESS



INDUSTRIAL

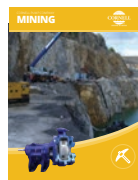

MINING



MUNICIPAL

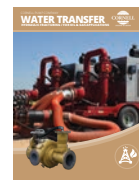

WATER
TRANSFER



REFRIGERATION

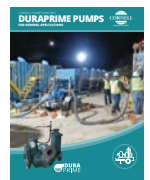

CONSTRUCTION

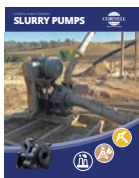

SLURRY

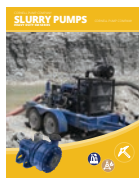

SLURRY SM

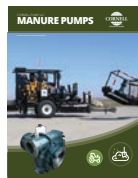

MANURE

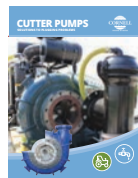

CUTTERS

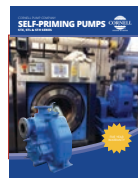

SELF PRIMING

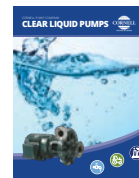

CLEAR LIQUIDS



MX SERIES

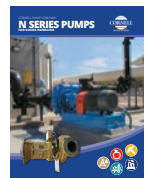

N SERIES

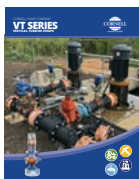

CYCLONE™

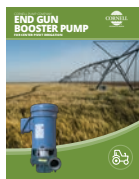

EDGE™



HYDRAULIC
SUBS

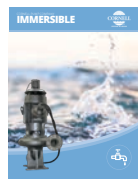

IMMERSIBLE



CD4MCU



RUN-DRY™



PRIMING
SYSTEMS

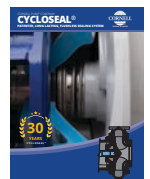

CYCLOSEAL®

Cycloseal® and Redi-Prime® are Registered Trademarks of Cornell Pump Company.

Cornell pumps and products are the subject of one or more of the following U.S. and foreign patents:

6,074,554; 6,036,434; 6,079,958; 6,309,169; 6,104,949.

23 - EV - BR - 901

CORNELLPUMP.COM
©2023 CORNELL PUMP COMPANY



Certified to
ISO 9001:2015



Cornell Pump Company
Clackamas, Oregon, USA
P: +1 (503) 653-0330
F: +1 (503) 653-0338

SOURCE
Bespoke Pumping Solutions



Source Pumps PTY LTD
22 Peterpaul Way
Truganina, VIC 3029
sourcepumps.com.au
sales@sourcepumps.com.au